

Crown Casino



Victorian Commission
for Gambling Regulation

Sic Bo Rules

RULES OF THE GAME

SIC BO

	PAGE NO
1 DEFINITIONS.....	1
2 EQUIPMENT	2
3 PLACEMENT OF WAGERS.....	3
4 PERMISSIBLE WAGERS.....	10
5 DEALING THE GAME	11
6 SETTLEMENT	12
7 IRREGULARITIES.....	13
8 TOURNAMENT PLAY.....	14
9 GENERAL PROVISIONS.....	17
Diagram A.....	19
Diagram B.....	20
Diagram C.....	21
Diagram D	22
Diagram E.....	23
Diagram F.....	24

RULES FOR SIC-BO

1 DEFINITIONS

1.1 In these Rules-

"Dealer" means the person, employed as a Dealer, by the casino operator, who is conducting the game.

"Distinctive Marker" means a marker button labelled with, but not limited to, the words personal limit or higher limit.

"Game Supervisor" means the person, employed as a game supervisor by the casino operator, who is supervising the conduct of the game.

"Spin" means an activation of the dice tumbler that causes the dice to be tumbled.

"Total" means the sum total of the uppermost sides of the three dice resulting from a valid spin.

"tournament" means a competition conducted in accordance with rule 8.

"tournament conditions" means the conditions approved for a tournament in accordance with rule 8.

"Tournament Director" means the person responsible for the overall management of a tournament.

"tournament player" means a person in a tournament.

"VCGR" means Victorian Commission for Gambling Regulation.

1.2 Unless contrary intention appears, a Game Supervisor **(or above)** may perform any function or exercise any power of the Dealer.

1.3 A reference in these rules to the game is a reference to the game of Sic Bo played at a particular gaming table.

1.4 A reference in these rules -

1.4.1 To a bet is a reference to the contingency or outcome on which a player may place a wager; and

1.4.2 To a wager is to the money appropriated to such a bet in a particular case.

2 EQUIPMENT

2.1 There are two options for playing the game of Sic Bo, Option A will utilise a table layout similar to that described in Diagram A, B, E or F and Option B will utilise a table layout similar to that described in Diagram C or D.

2.2 The table layout used for play:

2.2.1 Will -

(a) Contain all the elements of the design set out in Diagram A, B, C, D, E or F as applicable; and

(b) Contain any additional elements necessarily required by these rules; and

(c) Be of a similar appearance to Diagram A, B, C, D, E or F as applicable.

2.2.2 May include features in addition to those shown in Diagram A, B, C, D, E or F, if those features are not inconsistent with Diagram A, B, C, D, E or F, or these rules.

2.2.3 Will be fitted with electronic equipment to illuminate the winning areas on the layout.

2.3 The table will be fitted with:

2.3.1 A dice tumbler mechanically or electronically activated used to tumble the dice; and

2.3.2 A control panel linked to the dice tumbler with switches or buttons which will, where the game is played in accordance with:

(a) Option A, be numbered 1, 2, 3, 4, 5 and 6.

- (b) Option B, be labelled with the symbols Fish, Prawn, Gourd, Coin, Crab and Chicken.

2.4 A set of three (3) dice sealed in the dice tumbler.

2.4.1 The sides of each die will be marked as follows:

- (a) Where the game is played in accordance with Option A, with the values from one (1) to six (6), so arranged that the sum of the values of any pair of opposite sides is seven; or
- (b) Where the game is played in accordance with Option B, each face of the die will be marked with one (1) of six (6) different symbols, the symbols being Fish, Prawn, Gourd, Coin, Crab and Chicken. In accordance with (ii) below, the symbols will be arranged so that sum of the values of any pair of opposite sides of the dice is seven.
 - (i) Each symbol will represent one of the colours red, blue or green as follows: Fish (red), Prawn (green), Gourd (blue), Coin (blue), Crab (green) and Chicken (red).
 - (ii) Each Symbol will also represent one of the values one (1) to six (6) as follows: Fish (1), Prawn (2), Gourd (3), Coin (4), Crab (5) and Chicken (6).

3 PLACEMENT OF WAGERS

3.1 Wagers will only be accepted in chips. Chips used for play on the game may be either:

3.1.1 Cash chips marked with denominations of value; or

3.1.2 Colour chips, which are non-value chips without denomination markings.

- (a) The colour chips of a particular set will each bear the same distinguishing emblem or mark to differentiate them from colour chips of other sets in use at other tables. Each set will be subdivided into various colours.
- (b) Colour chips issued at a particular Sic Bo table will only be used for gaming at that table and will not be used for gaming at any other table in the casino.

- (c) The Dealer may accept a colour chip/s for redemption only if:
 - (i) The colour chip/s was issued at that particular table; or
 - (ii) The colour chip/s was issued at a table that is now closed. In this situation Surveillance will be notified and the value at which the colour chip/s was initially issued will, where possible be determined. If the initial value of the colour chip/s cannot be established, they will be exchanged at the lowest table minimum offered by the casino for the particular game played at the closed table at the time the player requests redemption. The exchange will be verified by a Pit Boss (or above).
- (d) The Dealer will not issue colour chips with the same colour and design to more than one player at the same time unless the particular players issued with the chips agree.
- (e) The specific value to be assigned to each chip will be declared by the purchaser. If that value exceeds the table minimum it will be denoted by a colour chip and a related marker button bearing a number on it to designate the value set by that person.
- (f) At the discretion of a **Pit Boss (or above)**, a player may be issued with colour chips of more than one colour at the same table provided no other player as a result is precluded from wagering with colour chips.
 - (i) In such instances the colours issued may be of different values providing the value of each colour is declared by the purchaser according to 3.1.2 (e).

3.2 Until a decision and settlement has been made in respect of any wager, no wager may be handled, placed, changed or withdrawn after the Dealer has announced that no more bets may be placed.

3.3 Wagers orally declared will only be accepted if they are accompanied by chips, authorised tokens, cash or vouchers. Cash, vouchers, and authorised tokens must be converted to chips prior to being placed on the layout. All wagers must be placed on the layout before the Dealer announces that no more bets may be placed.

- 3.4 Players are responsible for the positioning of their wagers on the layout, whether or not they are assisted by the Dealer. They must ensure that any instructions given to the Dealer are correctly carried out.
- 3.5 Wagers will be settled strictly in accordance with the position of chips when the result of a spin is announced.
- 3.6 At the settlement of wagers for a spin, the Dealer must—
- (a) Clear any losing wagers; and
 - (b) Pay any winning wagers.
- 3.7 Wagers may be placed on:
- 3.7.1 Where the game is played according to Option A and on a table layout similar to diagram A or B:

- (a) Big;
- (b) Small;
- (c) Specific Triples;
- (d) Specific Doubles;
- (e) Any Triple;
- (f) Three Dice Totals;
- (g) Two Dice Combinations; and
- (h) Single Die.

- 3.7.2 Where the game is played according to Option A and on a table layout similar to diagram E or F, in addition to those wagers described in 3.7.1 above, wagers may also be placed on:

- (a) Odd;
- (b) Even; and
- (c) 3 of 4 Dice

3.7.3 Where the game is played according to Option B:

- (a) Big;
- (b) Small;
- (c) Specific Symbol Triples;
- (d) Specific Colour Triples;
- (e) Any Symbol Triple;
- (f) Any Colour Triple;
- (g) Three Dice Totals;
- (h) Specific Colour Double;
- (i) Single Colour; and
- (j) Single Symbol.

3.8 A wager placed on 'Small' by a player will:

3.8.1 Win if the result is any of the totals 4, 5, 6, 7, 8, 9 or 10 in any combination of the three dice; and

3.8.2 Lose when the result is a triple or any other total.

3.9 A wager placed on 'Big' by a player will:

3.9.1 Win if the result is any of the totals 11, 12, 13, 14, 15, 16 or 17 in any combination of the three dice; and

3.9.2 Lose if the result is a triple or any other total.

3.10 A wager placed on a 'Specific Triple' will:

3.10.1 Where the game is played in accordance with Option A, win if the result is any one of the specific triples 6, 5, 4, 3, 2 or 1 as nominated by the player placing the wager.

3.10.2 Where the game is played in accordance with Option B, win if the result is:

- (a) Any one of the specific triples Fish, Prawn, Gourd, Coin, Crab and Chicken, as nominated by the player placing the wager;
- (b) Any one of the specific colour triples red, green or blue, as nominated by the player placing the wager.

3.10.3 Lose on any combination other than those described in rule 3.10.1 and 3.10.2 above.

3.11 A wager placed on a 'Specific Double' will:

3.11.1 Where the game is played in accordance with Option A, win if the result is any one of the specific doubles 6, 5, 4, 3, 2 or 1 as nominated by the player placing the wager; or

- (i) For the result to constitute a double, 2 or all 3 dice must display the same specific number on their uppermost face.
- (ii) Where all 3 dice display the same specific number this will constitute one double only with respect to a wager placed on "Specific Double" and not three doubles that can be attained from all possible combinations of the dice. The wager will be paid once only.

3.11.2 Where the game is played in accordance with Option B, win if the result is any one of the specific doubles red, blue or green as nominated by the player placing the wager;

- (i) For the result to constitute a double, 2 or all 3 dice must display the same specific colour on their uppermost face.
- (ii) Where all 3 dice display the same specific colour this will constitute one double only with respect to a wager placed on 'Specific Double' and not three doubles that can be attained from all possible combinations of the dice. The wager will be paid once only.

3.11.3 Lose on any combination other than those described in rule 3.11.1 and 3.11.2 above.

- 3.12 A wager placed on 'Any Triple' by a player will:
- 3.12.1 Where the game is played in accordance with Option A, win if the result is any triple 6, 5, 4, 3, 2 or 1;
 - 3.12.2 Where the game is played in accordance with Option B, win if the result is any triple Fish, Prawn, Gourd, Coin, Crab and Chicken;
 - 3.12.3 Where the game is played in accordance with Option B, win if the result is a triple of any colour (i.e. triple red, triple green or triple blue); and
 - 3.12.4 Lose on any combination other than those described in rule 3.12.1 to 3.12.3 above.
- 3.13 A wager placed on a 'Three Dice Total' means a wager placed by the player on any one of the specific totals 4, 5, 6, 7, 8, 9, 10, 11, 12, 13, 14, 15, 16 or 17 which will:
- 3.13.1 Win if the result is that total in any combination of the three dice; and
 - 3.13.2 Lose on any other total.
- 3.14 A wager placed on a 'Two Dice Combination' means a wager placed by the player on one of the specific combinations that will:
- 3.14.1 Win when two of the 3 dice display on their uppermost face the specific numbers as selected by the player; and
 - 3.14.2 Lose on any other combination.
- 3.15 A wager placed on 'Single Die' or 'Single Symbol' means a wager placed by the player:
- (a) Where the game is played in accordance with Option A on any one of the numbers 1, 2, 3, 4, 5 or 6; or
 - (b) Where the game is played in accordance with Option B on any one of the symbols Fish, Prawn, Gourd, Coin, Crab and Chicken

which will win if that specific number or symbol, as the case may be is displayed on the uppermost face of one or more of the dice; and lose if that specific number or symbol as the case may be is not displayed on one or more of the dice.

3.16 A wager on 'Single Colour' means a wager placed by the player on any one of the colours red, green or blue; which will win if that specific colour is displayed on the uppermost face of one or more of the dice; and lose if that specific colour, is not displayed on one or more of the dice.

3.16.1 Where 2 or 3 dice display the same specific colour, this will constitute one result only with respect to a wager placed on 'Single Colour' and not two or three individual results. i.e. the wager will be paid once only in accordance with rule 6.

3.17 A wager placed on 'Odd' will:

3.17.1 Win if the result is any of the totals 5, 7, 9 11, 13, 15 or 17 in any combination of the three dice; and

3.17.2 Lose when the result is a triple or any other total.

3.18 A wager placed on 'Even' will:

3.18.1 Win if the result is any of the totals 4, 6, 8, 10, 12, 14, or 16 in any combination of the three dice; and

3.18.2 Lose when the result is a triple or any other total.

3.19 A wager placed on '3 of 4 Dice' will:

3.19.1 Win when the three dice display on their uppermost face three of the four numbers comprising the four dice combinations of 6,5,4,3 or 6,5,3,2 or 5,4,3,2 or 4,3,2,1 as selected by the player; and

3.19.2 Lose on any other combination.

3.20 Wagers may only be placed in accordance with rule 3.

4. PERMISSIBLE WAGERS

- 4.1 In respect of the game, the Dealer must ensure the display of the notices and signs for which the casino operator is responsible under section 66 of the **Casino Control Act 1991**¹.
- 4.2 If—
- 4.2.1 A player attempts to place an individual wager that is less than the minimum permissible wager for a particular bet, the wager will be paid or collected after the result and the owner of the wager will be advised that further wagers under the minimum will be returned regardless of the result;
- 4.2.2 A player attempts to place an individual wager which is greater than the permitted maximum wager the wager will be paid or collected to the maximum;
- 4.2.3 A player attempts to place an individual wager in a multiple over the minimum which is not permitted or where it is not possible to pay the wager exactly in chips it will be paid to the next highest amount to which payment can be made in chips.
- 4.3 Minimum and maximum wagers which differ from those displayed on the table limit sign may be agreed for individual players and in such cases, the position occupied by the player will be noted by a distinctive marker.

Victorian Commission
for Gambling Regulation

¹ Sections 66 of the **Casino Control Act 1991** state:

66. Assistance to patrons

- (1) A casino operator must—

...

- (c) display prominently at each gaming table or location related to the playing of a game a sign indicating the permissible minimum and maximum wagers pertaining to the game played there.

Penalty: 25 penalty units.

- (2) A casino operator must ensure that a minimum wager indicated in respect of a game at a table or location is not changed to a higher minimum unless a sign indicating the new minimum and the proposed time of change is displayed at the table or location at least 20 minutes before the time of proposed change.

Penalty: 50 penalty units.

5 DEALING THE GAME

5.1 The Dealer will:

- 5.1.1 Announce to the players that they may place their bets.
- 5.1.2 Cover and activate the dice tumbler causing the dice to be tumbled within the dice tumbler.
- 5.1.3 Announce to the players that no more bets may be placed.
- 5.1.4 Uncover the dice tumbler.
- 5.1.5 Announce the result by calling the uppermost face of each die. Where one or more die is not lying flat, announce that the spin is a no spin, cover and reactivate the dice tumbler.
 - (a) Where the game is played in accordance with Option A, the dice will be called in order, from the smallest number to the highest and then the total of the three dice.
 - (b) Where the game is played in accordance with Option B, the symbol on each die will be announced.
- 5.1.6 At the same time as announcing the winning result enter the winning numbers or symbols, as the case may be, into the control panel causing the winning areas on the layout to be illuminated.
- 5.1.7 When the winning areas have been illuminated take all losing wagers and pay all winning wagers in accordance with rule 6.
- 5.1.8 **When there are no wagers on the layout, or players present at the table, the Game Supervisor (or above) may direct the Dealer to activate the dice tumbler one or more times. Each time the dice tumbler is activated, the Dealer will ensure compliance with the requirements of rules 5.1.1 to 5.1.6 (inclusive). The dice tumbler may be activated in the following circumstances:**
 - (a) **Once the table has been open for play; or**
 - (b) **At any time during the course of play; or**
 - (c) **Continuously until a player places a wager at the table.**

5.2 No person other than a Dealer (**or above**) who is responsible for the operation of the game, will activate the dice tumbler or operate the control panel.

6 SETTLEMENT

6.1 The bets which may be placed in respect of a round of play when Option A is in play and the odds payable for them are-

Table 1 Payout Odds Option A

Name		Odds
Small		1 to 1
Big		1 to 1
Specific Triples		180 to 1
Specific Doubles		11 to 1
Any Triple		31 to 1
Three Dice Totals	4 or 17	62 to 1
	5 or 16	31 to 1
	6 or 15	18 to 1
	7 or 14	12 to 1
	8 or 13	8 to 1
	9 or 12	7 to 1
	10 or 11	6 to 1
Two Dice Combinations	1&2, 1&3, 1&4, 1&5, 1&6 2&3, 2&4, 2&5, 2&6 3&4, 3&5, 3&6 4&5, 4&6 5&6	6 to 1
Single Die Bet	Number on one Die	1 to 1
	Number on two Dice	2 to 1
	Number on three Dice	12 to 1
Additional Wagers		
Even		1 to 1
Odd		1 to 1
3 of 4 Dice	6,5,4,3, 6,5,3,2, 5,4,3,2, 4,3,2,1	7 to 1

- 6.2 The bets which may be placed in respect of a round of play when Option B is in play and the odds payable for them are-

Table 2 Payout Odds Option B

Name	Odds	
Small	1 to 1	
Big	1 to 1	
Specific Symbol Triples	180 to 1	
Specific Colour Triples	23 to 1	
Any Symbol Triple	31 to 1	
Any Colour Triple	7 to 1	
Specific Colour Double	3 to 1	
Single Colour	1 to 1	
Three Dice Totals	4 or 17	62 to 1
	5 or 16	31 to 1
	6 or 15	18 to 1
	7 or 14	12 to 1
	8 or 13	8 to 1
	9 or 12	7 to 1
	10 or 11	6 to 1
Single Symbol	Symbol on one Die	1 to 1
	Symbol on two Dice	2 to 1
	Symbol on three Dice	12 to 1

7 IRREGULARITIES

- 7.1 The Dealer will announce that a spin is a no spin when:

- 7.1.1 Any of the three dice are not lying flat in the bottom section of the dice tumbler after the dice have been tumbled in accordance with rule 5.1.2; or
- 7.1.2 After being activated the dice tumbler malfunctions; or
- 7.1.3 In the event that the dice are exposed before the Dealer has announced that no more bets may be placed.

- 7.2 In the event the Dealer has announced a no spin, the dice tumbler will be reactivated.
- 7.3 If the electronic equipment fails to illuminate the winning areas on the layout or fails to illuminate the winning areas correctly, all wagers will be taken and paid according to the result shown on the dice.
- 7.4 Where a malfunction occurs, the Pit Boss (**or above**) will be notified. Where the malfunction cannot be corrected immediately, no further play will be permitted until the fault has been rectified.
- 7.5 If during a round of play an error occurs that is not disclosed until after the commencement of a subsequent round of play, that error will not have any effect on the outcome of subsequent rounds of play.

8 TOURNAMENT PLAY

8.1 General

- 8.1.1 The casino operator may conduct tournaments in which all tournament players have the opportunity to play Sic Bo with an equal chance.
- 8.1.2 The casino operator must appoint a Tournament Director.
- 8.1.3 A tournament may only be conducted if the conditions for the tournament, complying with these rules, have been approved in writing by the Executive Commissioner of the VCGR.

8.2 Tournament conditions

- 8.2.1 The tournament conditions must include the following—
- (a) The amount of the entry fee, if any;
 - (b) The amount of tournament chips to be allocated to the player at the commencement of a session;
 - (c) Whether there is a minimum or compulsory wager for each round of play in a session or round;
 - (d) The structure of the tournament, including the number and duration of rounds or sessions and the number of gaming tables to be active in each round or session, the method of progression from round to round or session to session; repechage, catch-up or secondary rounds or sessions;

- (e) Whether there is one or more opportunities for an eliminated tournament player to buy back into the tournament, and the method and timing of those opportunities;
- (f) In respect of eligibility for entry—
 - (i) A statement that only persons entitled to enter the casino and gamble are eligible to enter the tournament; and
 - (ii) If the casino operator is reserving the right generally to deny entry to the tournament, a statement that the casino operator may refuse any application; and
 - (iii) If the casino operator is applying general selection criteria to determine eligibility to enter the tournament, those criteria;
- (g) The terms of entry (including the period within which an applicant may withdraw without financial penalty), the application form and the minimum and maximum numbers of tournament players;
- (h) The basis on which a tournament player may be disqualified from the tournament or on which a tournament player may retire from the tournament and whether or not any entrance fee or buy in is refundable in whole or in part;
 - (i) The consequences of late arrival or non-attendance for a round or session in the tournament;
 - (j) The prizes;
 - (k) A statement that the tournament is conducted by the Tournament Director in accordance with the tournament conditions and the applicable rules of Sic Bo and that, in the event of any inconsistency, the rules prevail.

8.2.2 Prior to the commencement of play in a tournament, the Tournament Director must brief the tournament players on the conditions of the tournament and be satisfied that they understand.

8.2.3 The Tournament Director may require each tournament player to sign a copy of the tournament conditions.

8.2.4 The Tournament Director must be present during the whole of each session or round of play in a tournament.

8.3 Conduct of Play

8.3.1 The Tournament Director must designate the gaming tables to be used in the conduct of the tournament.

8.3.2 The casino operator must ensure that, during any session or round of a tournament, a gaming table designated under rule 8.3.1 is used exclusively for tournament play.

8.3.3 A tournament player may nominate, subject to the approval of the Tournament Director and any applicable tournament condition, a substitute player to take his or her allotted position during any session or round.

8.3.4 The Tournament Director may alter the starting time of any session, if reasonable notice has been given to the tournament players.

8.3.5 The Tournament Director may conclude the play of a session or round at a particular gaming table prior to the completion of the scheduled number of spins or the scheduled completion time—

Victorian Commission
for Gambling Regulation

(a) If the tournament player or players to progress to the following session from that gaming table or round have been determined; and

(b) If the tournament conditions provide for the disposition of tournament chips in cash at the end of the session or round, if all the players at the gaming table agree.

9 GENERAL PROVISIONS

- 9.1 A person will not, either alone or in concert with any other person, use or have in his/her possession or control at or near a gaming table or location related to the playing of a game a calculator, computer, or other electronic, electrical or mechanical apparatus or device that is capable, with respect to a game or a part thereof, of recording, projecting or analysing an outcome or the changing probabilities or the playing strategies to be used.
- 9.2 Where a player has contravened any provision of the rules a **Pit Boss (or above)** may:-
- 9.2.1 Declare that any wager made by the player/s will be void;
 - 9.2.2 Direct that the player/s will be excluded from further participation in the game;
 - 9.2.3 Seize any monies won by that player/s while in possession of a prohibited device and retain such monies pending completion of an investigation;
 - 9.2.4 Confiscate the prohibited device; and
 - 9.2.5 Cause the person/s in possession of the prohibited device to be detained in accordance with section 81 of the **Casino Control Act 1991**.
- 9.3 A **Pit Boss (or above)** may invalidate the outcome of a game if:-
- 9.3.1 The game is disrupted by civil commotion, fire, riot, brawl, robbery, an or Act of God; or
 - 9.3.2 Any fraudulent act is perpetrated by any person that affects the outcome of the game.
- 9.4 Where the outcome of a game is invalidated, all wagers made by the players for that particular result will be refunded.
- 9.5 A player will not be advised by an employee of the casino on how to play, except to ensure compliance with these rules.
- 9.6 No onlooker or any player wagering at any table may, unless requested by a player, influence another players decisions of play.

- 9.7 The **Pit Boss (or above)** may close a gaming table at which players are present provided a sign showing the proposed time of closure has been displayed at the table for at least 20 minutes before the closure.
- 9.8 A player who abstains from wagering for three consecutive rounds whilst all other positions at that table are in use may be required to vacate that area.
- 9.9 In any dispute arising from these rules or not covered by the provisions of these rules, the decision of the **Pit Boss (or above)** will be final.
- 9.10 Complainants in all unresolved disputes will be advised of the presence of, and their right to consult an inspector appointed under the **Casino Control Act 1991**.
- 9.11 Players are not permitted to have side bets against each other.
- 9.12 A copy of these Rules will be made available upon request.



Victorian Commission
for Gambling Regulation

Diagram A

SMALL NUMBERS 4 TO 10 1 PAYS 1 ANY TRIPLE LOSES		EACH DOUBLE 1 PAYS 11 DOUBLE ONE DOUBLE TWO DOUBLE THREE			1 PAYS 180 TRIPLE ONE TRIPLE TWO TRIPLE THREE			1 PAYS 31 ANY TRIPLE			1 PAYS 180 TRIPLE FOUR TRIPLE FIVE TRIPLE SIX			EACH DOUBLE 1 PAYS 11 DOUBLE FOUR DOUBLE FIVE DOUBLE SIX			BIG NUMBERS 11 TO 17 1 PAYS 1 ANY TRIPLE LOSES	
4	5	6	7	8	9	10	11	12	13	14	15	16	17					
1 PAYS 62	1 PAYS 31	1 PAYS 18	1 PAYS 12	1 PAYS 8	1 PAYS 7	1 PAYS 6	1 PAYS 6	1 PAYS 7	1 PAYS 8	1 PAYS 12	1 PAYS 18	1 PAYS 31	1 PAYS 62					
1 PAYS 6 	1 & 2	1 & 3	1 & 4	1 & 5	1 & 6	2 & 3	2 & 4	2 & 5	2 & 6	3 & 4	3 & 5	3 & 6	4 & 5	4 & 6	5 & 6			
ONE	TWO	THREE	FOUR	FIVE	SIX													
1 TO 1 ON ONE DICE.... 2 TO 1 ON TWO DICE... 12 TO 1 ON THREE DICE																		

Victorian Commission
for Gambling Regulation

Diagram B

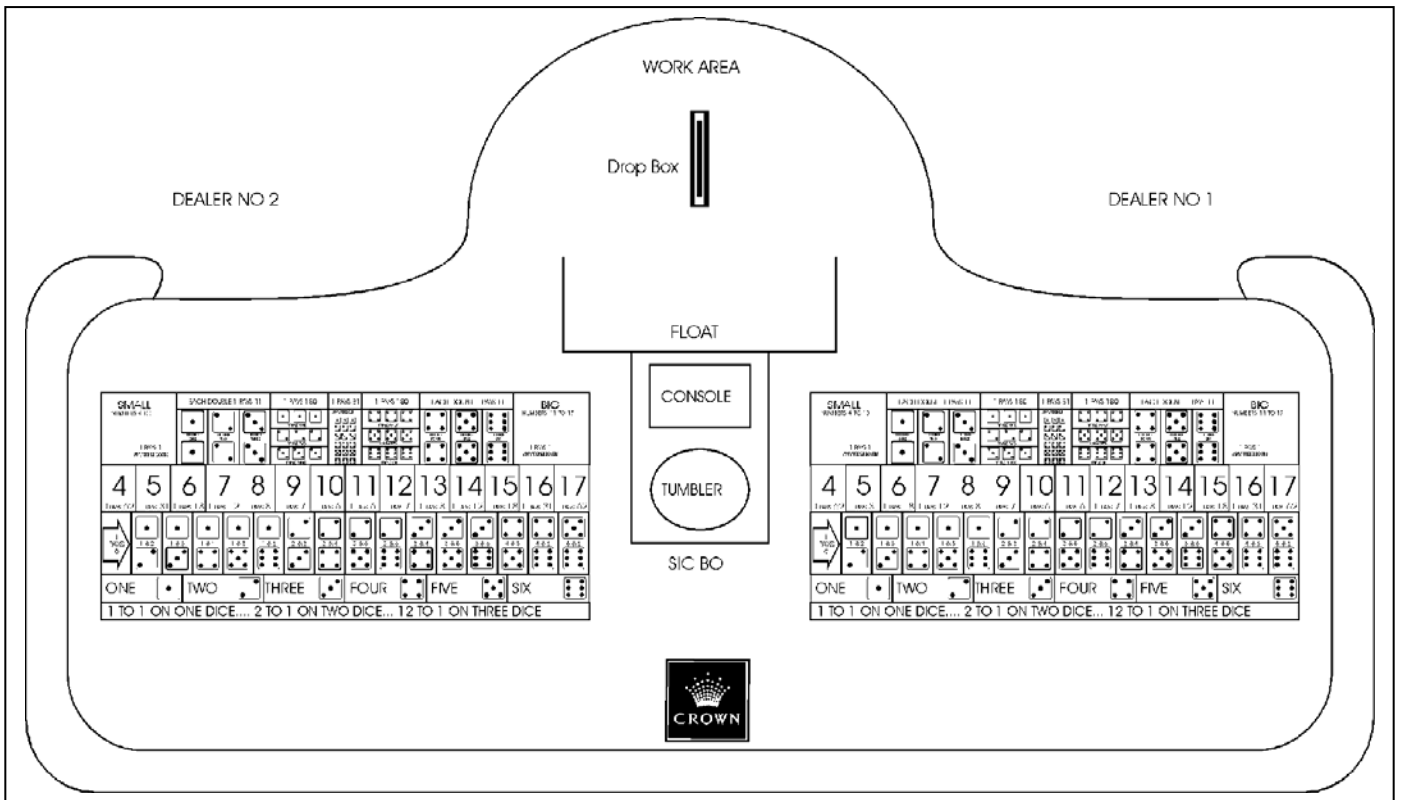

Diagram C

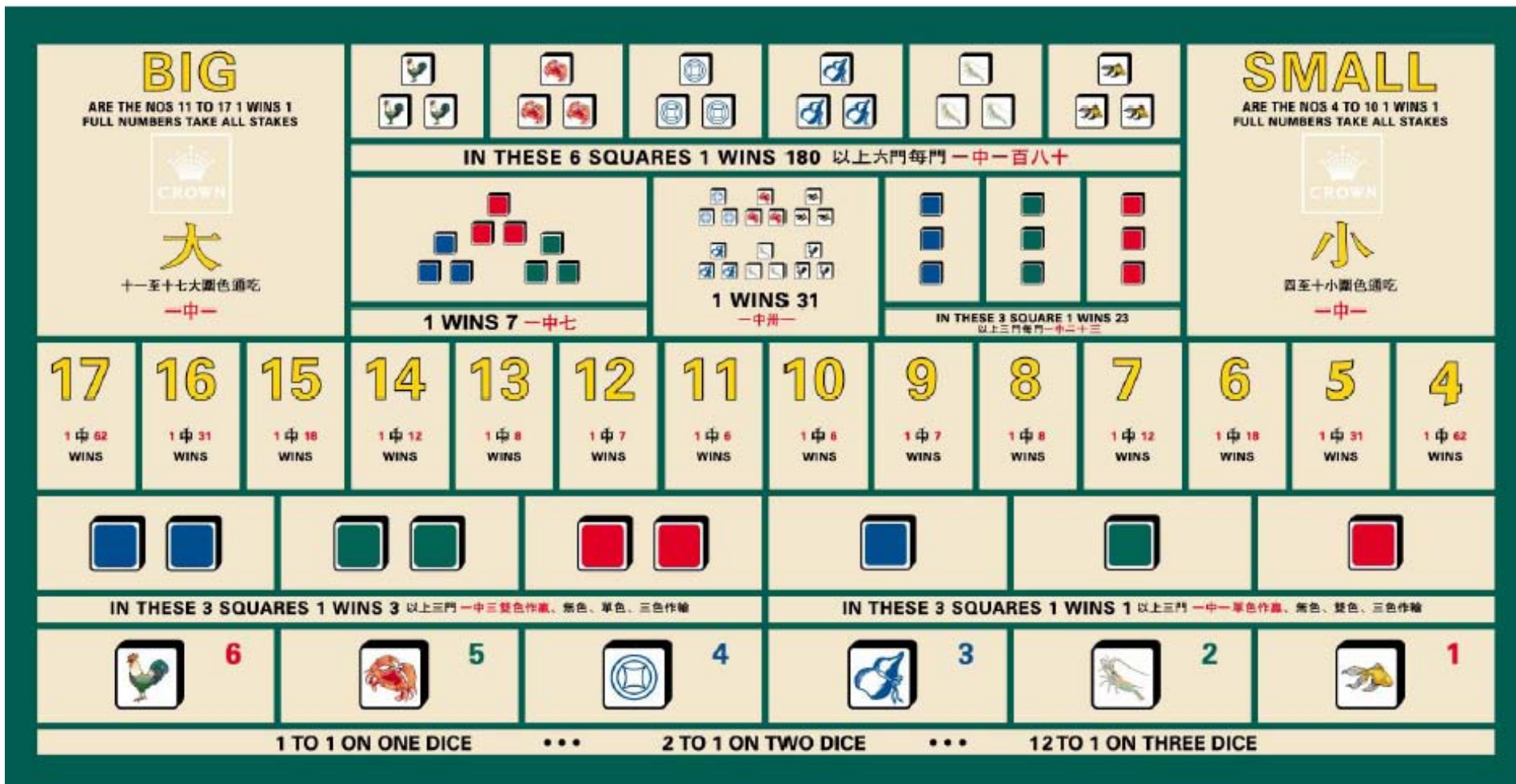
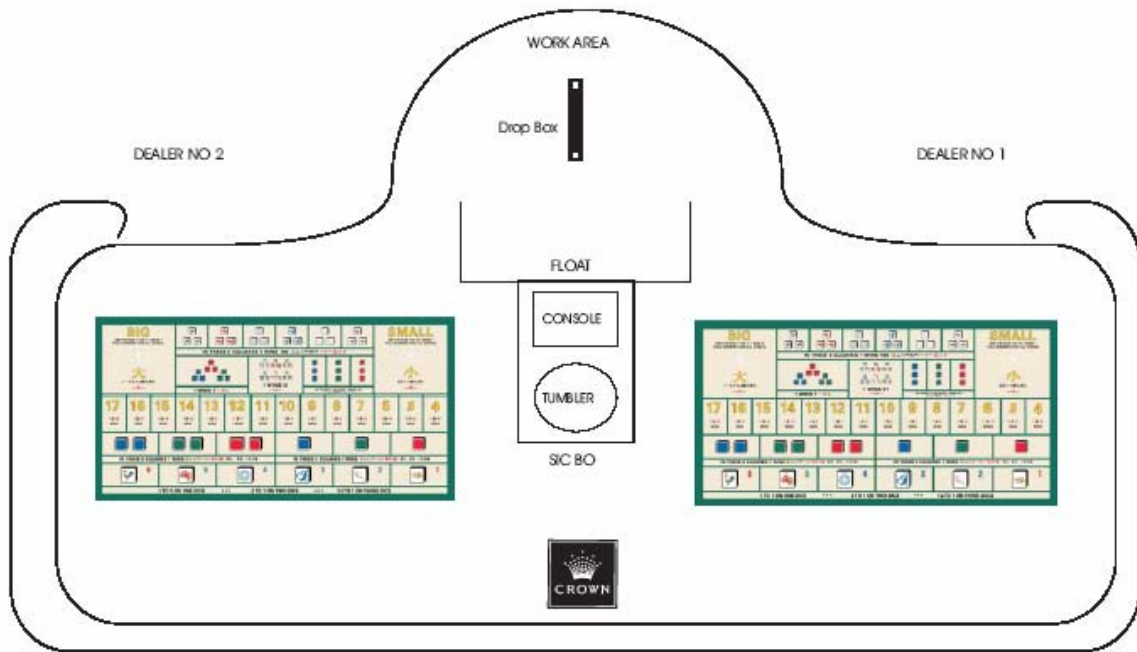

DIAGRAM D



for Gambling Regulation

Diagram E

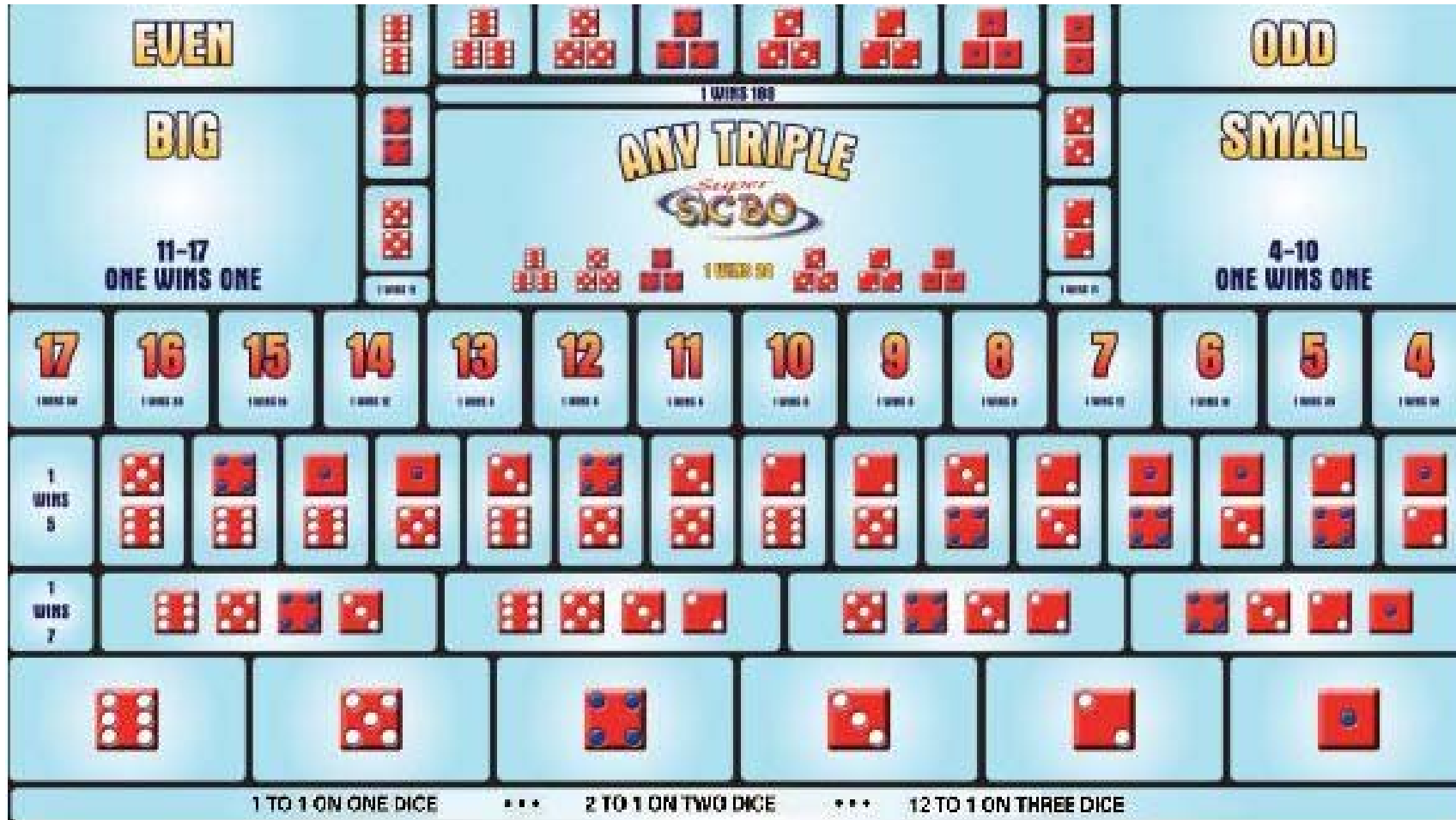
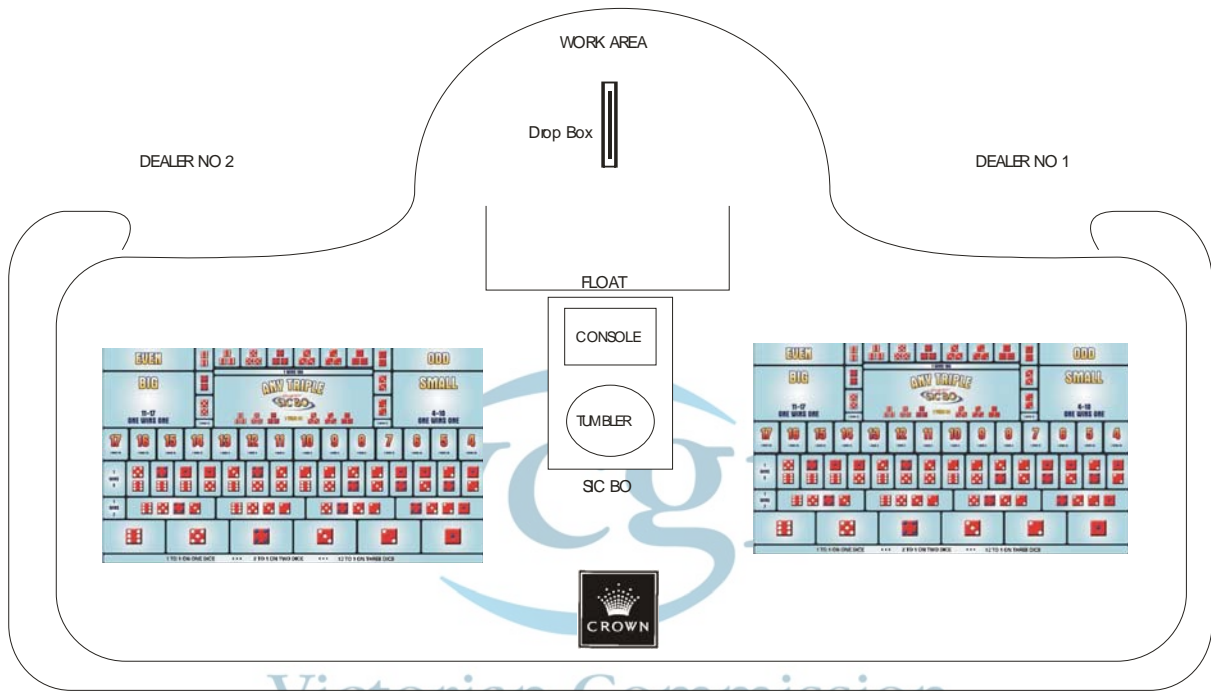

Diagram F



Victorian Commission
for Gambling Regulation